

# Hydromechanika a hydrológia

Prof. Ing. Karel Kovářík, PhD  
Katedra geotechniky  
Stavebná fakulta ŽU

Tel. 0905-659763

E-mail: [kovarik@fstav.uniza.sk](mailto:kovarik@fstav.uniza.sk)

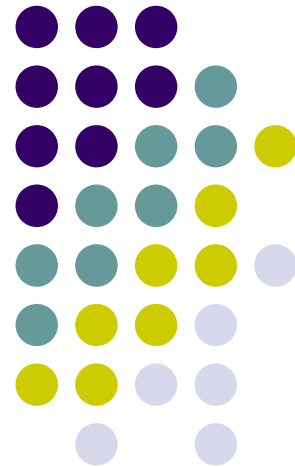

# Základné vlastnosti tekutín

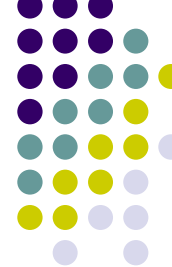

- Hustota  $\rho = \frac{m}{V}$

- Objemová teplotná rozťažnosť

$$\alpha = \frac{1}{V_0} \cdot \frac{\Delta V}{\Delta T} \Rightarrow V = V_0 \cdot (1 + \alpha \cdot \Delta T)$$

$\alpha$  – koeficient teplotnej rozťažnosti

Anomália vody – maximálna hustota pri 4°C

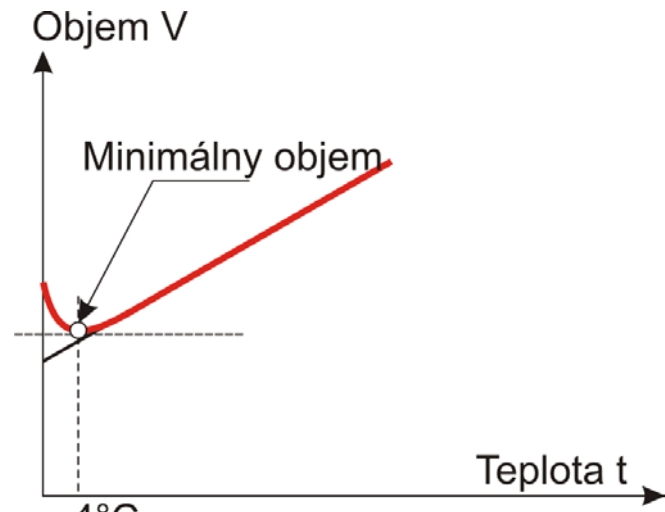

# Základné vlastnosti tekutín

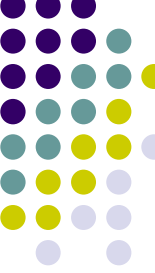

- Stlačiteľnosť

$$-\frac{\Delta V}{V} = \frac{\Delta p}{K} \Rightarrow V = V_0 \cdot (1 - \beta \cdot \Delta p)$$

$$V = V_0 \cdot \left( 1 - \frac{\Delta p}{K} \right)$$

$\beta$  – koeficient stlačiteľnosti [ $\text{Pa}^{-1}$ ]

$K$  – objemový modul stlačiteľnosti [ $\text{Pa}$ ]

# Základné vlastnosti (pokrač.)



- Viskozita

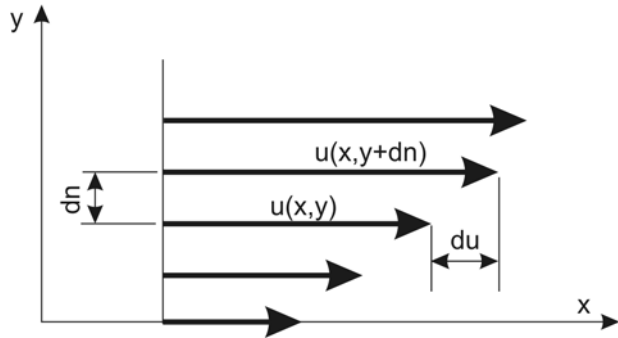

Newtonov zákon vnút. trenia

$$\tau = -\mu \frac{\partial u}{\partial n}$$

$\mu$  – koeficient dynamickej viskozity [Pa.s]  
 $\nu$  – koeficient kinematickej viskozity [m<sup>2</sup>.s<sup>-1</sup>]

$$\nu = \frac{\mu}{\rho}$$

# Druhy kvapalín

- Newtonské
- Neneutonské
  - rednúce
  - hustnúce
  - Binghamské

$$\tau = -\mu \cdot \left( \frac{du}{dy} \right)^n$$

$n > 1$  rednúce,  $n < 1$  hustnúce

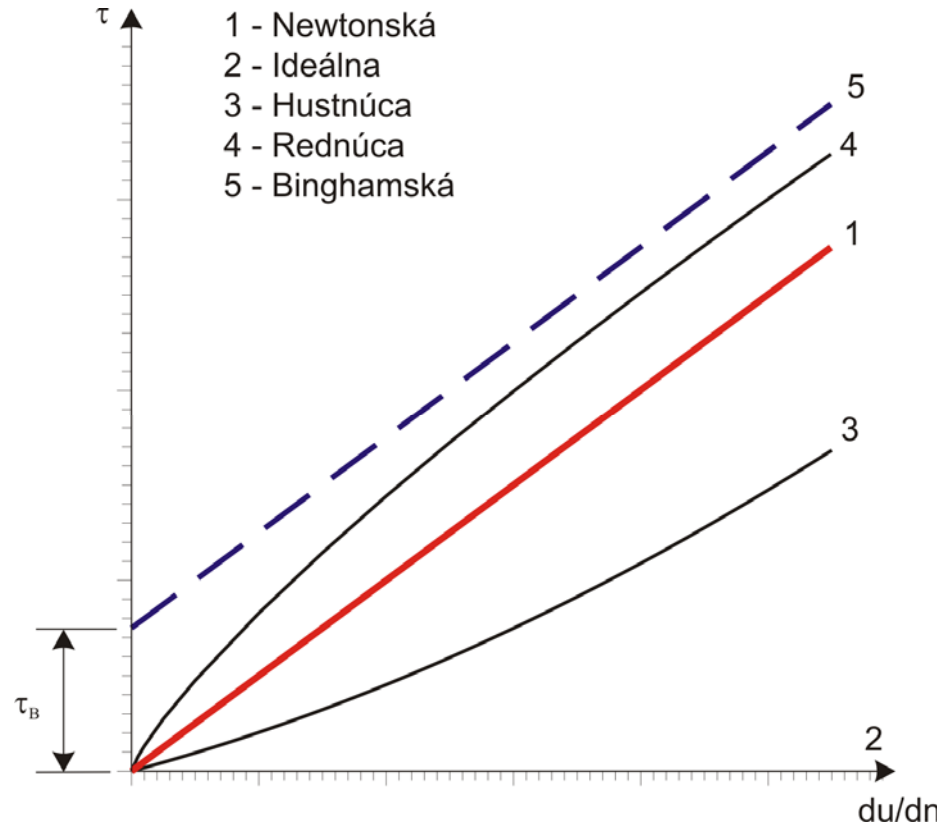

# Základné vlastnosti (pokrač.)



- Povrchové napätie

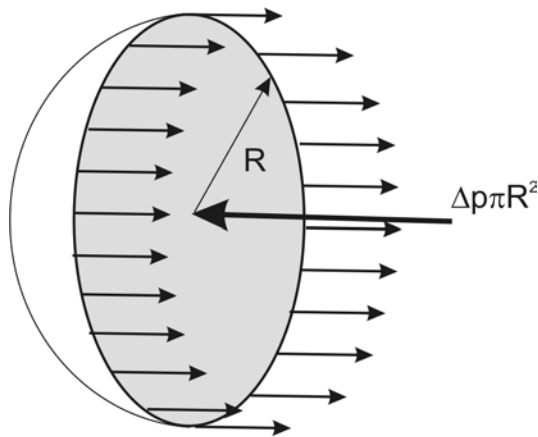

$$2\pi R\sigma = \Delta p\pi R^2$$

$$\Delta p = \frac{2\sigma}{R}$$

$\sigma$  – kapilárna konštanta [ $\text{N}\cdot\text{m}^{-1}$ ]

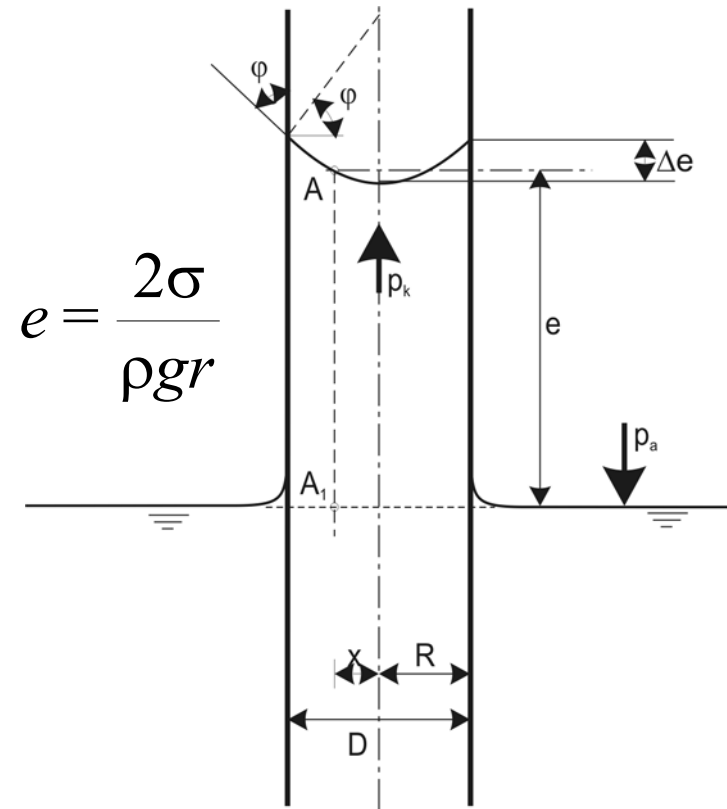

$$e = \frac{2\sigma}{\rho g r}$$

# HYDROSTATIKA

- Tlak v bode

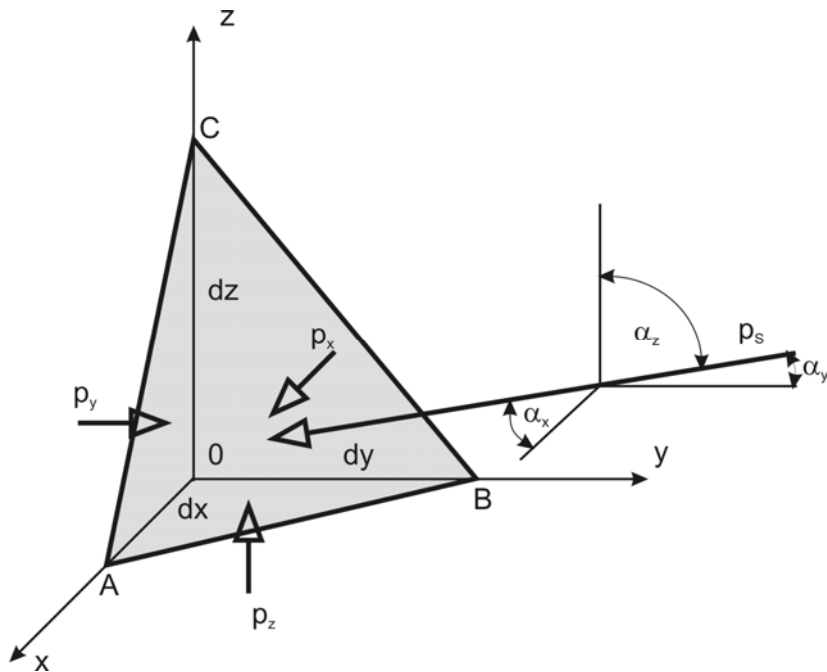

$$p = \frac{dF}{dS}$$

$$F_x = p_x \frac{dy \cdot dz}{2} \quad F_y = p_y \frac{dx \cdot dz}{2}$$

$$F_z = p_z \frac{dx \cdot dy}{2} \quad F_s = p dS$$

$$p_x \cdot \frac{dy \cdot dz}{2} - p \cdot dS \cdot \cos \alpha_x = 0$$

$$p_y \cdot \frac{dx \cdot dz}{2} - p \cdot dS \cdot \cos \alpha_y = 0$$

$$p_z \cdot \frac{dx \cdot dy}{2} - p \cdot dS \cdot \cos \alpha_z = 0$$

$$p_x = p_y = p_z = p$$

# Rovnice rovnováhy



- Eulerove rovnice rovnováhy

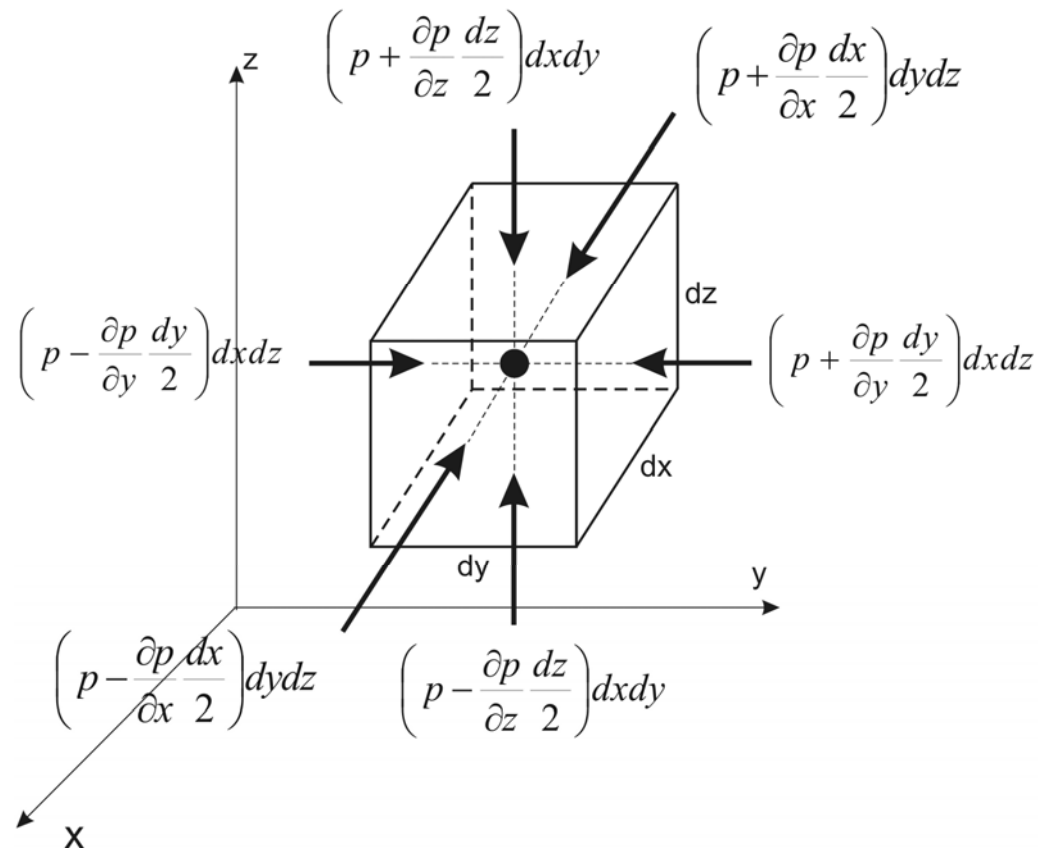

$$F_{xL} = \left( p + \frac{\partial p}{\partial x} \frac{dx}{2} \right) dydz$$

$$F_{xR} = - \left( p + \frac{\partial p}{\partial x} \frac{dx}{2} \right) dydz$$

$$F_{xV} = a_x \rho dx dy dz$$

$$-\frac{\partial p}{\partial x} + a_x \rho = 0$$

$$-\frac{\partial p}{\partial y} + a_y \rho = 0$$

$$-\frac{\partial p}{\partial z} + a_z \rho = 0$$



# Hydrostatický tlak

- Integráciou Eulerových rovníc

Predpoklad:  $a_x = a_y = 0, a_z = -g$

$$\frac{\partial p}{\partial x} = \frac{\partial p}{\partial y} = 0$$

$$-\frac{\partial p}{\partial z} = \rho g \Rightarrow dp = -\rho g dz$$

$$p = \rho \cdot g \cdot h + p_0$$

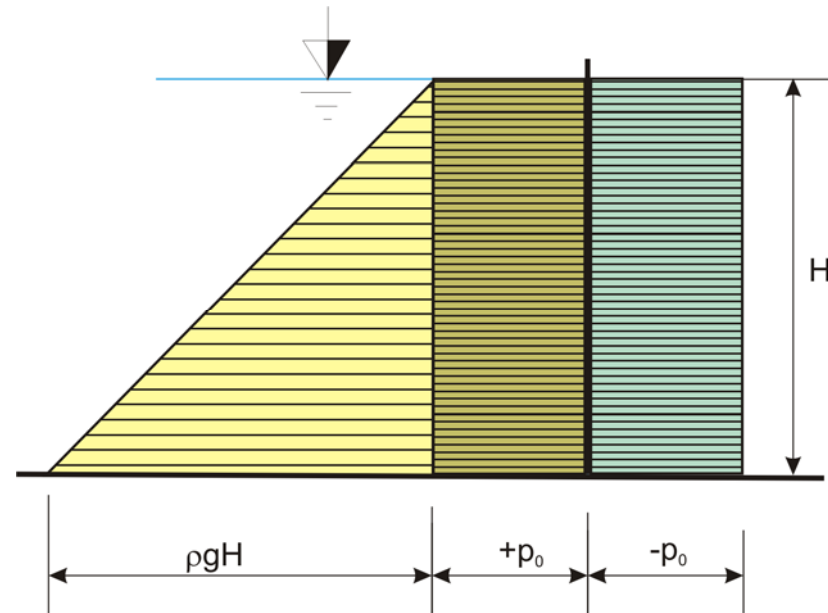

Tlak  $p_0$  často zanedbávame u stavebných konštrukcií

# Hydrostatický tlak

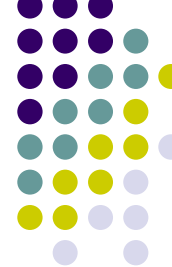

- Hydrostatické paradoxon

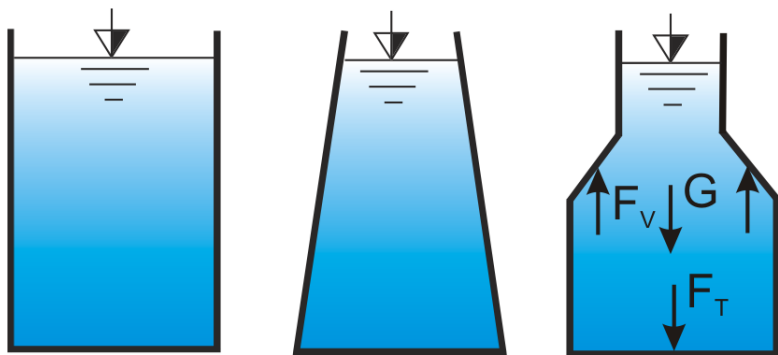

Hydrostatický tlak nie je závislý na tvare nádoby, ani na objeme kvapaliny v nej, ale iba na hĺbke a na druhu kvapaliny

$$F_T + G - F_V = 0 \Rightarrow F_T > G$$

# Tlak na steny



- Určenie výslednej tlakovej sily

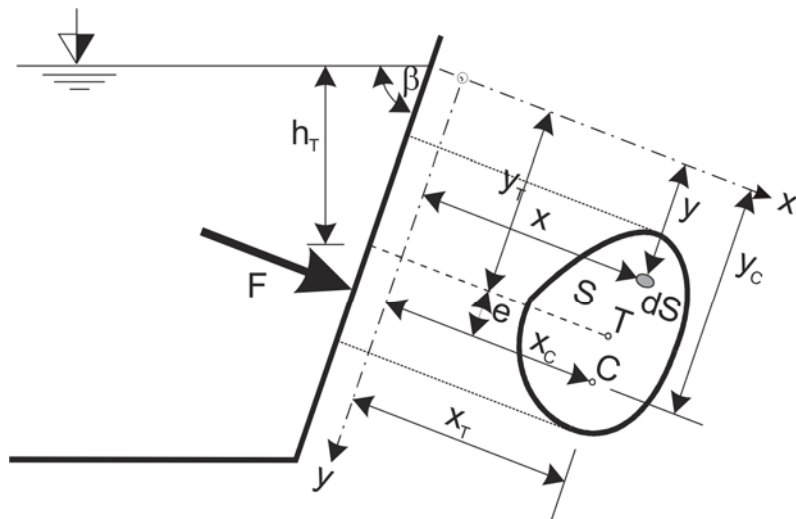

$$dF = p \cdot dS = \rho g h dS$$

$$F = \rho g \sin \beta \int_S y dS$$

$$F = \rho g y_T \sin \beta S = \rho g h_T S$$

Pôsobisko sily

$$y_c = \frac{\rho g \sin \beta J_x}{\rho g \sin \beta S y_T} = \frac{J_x}{S y_T} = \frac{J_x}{U_x}$$

$$x_c = \frac{\rho g \sin \beta D_{xy}}{\rho \sin \beta S y_T} = \frac{D_{xy}}{S y_T} = \frac{D_{xy}}{U_x}$$

# Tlaková sila – druhá metóda

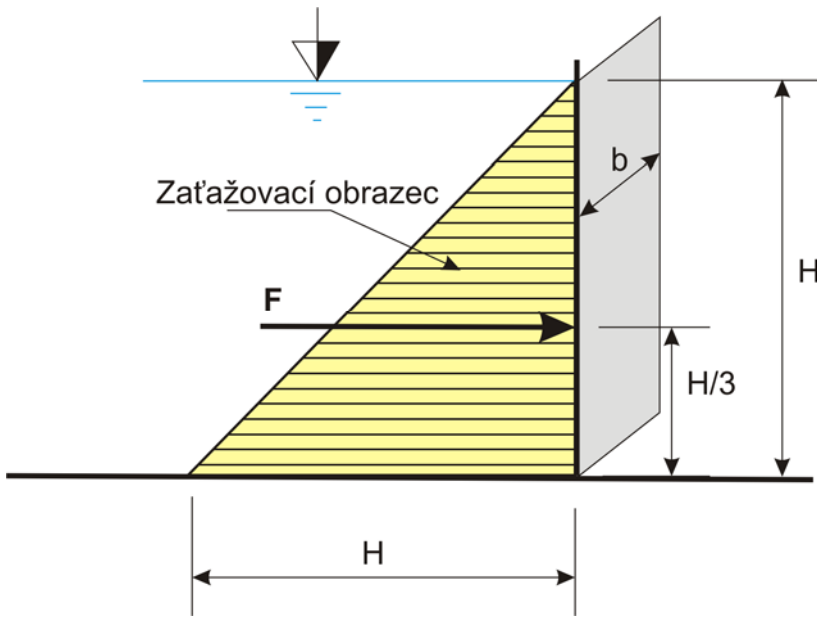

$$F = S_z \cdot b \cdot \rho \cdot g$$

$S_z$  – plocha zaťažovacieho obrazca

Pôsobisko sily je v ťažisku zaťažovacieho obrazca

# Tlaková síla

- Šikmá stěna

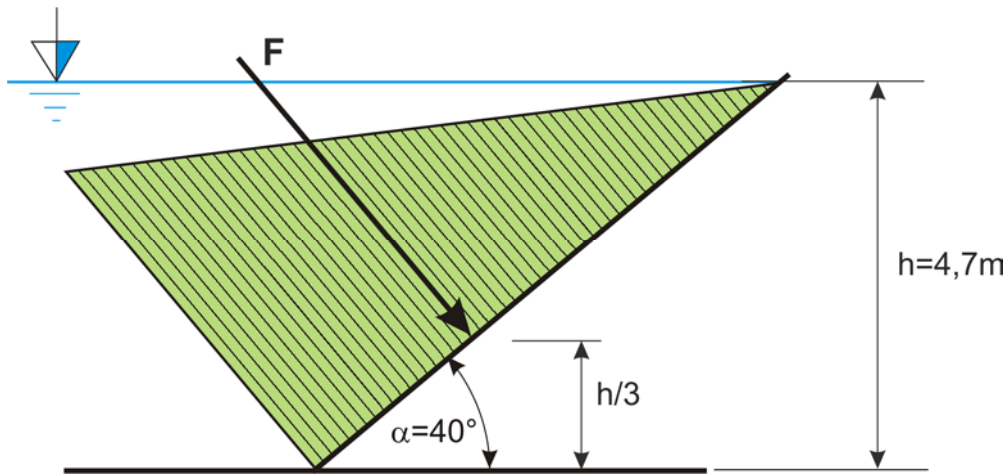

$$l = \frac{h}{\sin \alpha} = \frac{4,7}{\sin 40^\circ} = 7,311\text{m} \quad S_z = \frac{1}{2} \cdot l \cdot h = \frac{1}{2} \cdot 7,311 \cdot 4,7 = 17,182\text{m}^2$$

$$F = \rho \cdot g \cdot b \cdot S_x = 1000 \cdot 9,81 \cdot 1 \cdot 17,182 = 168,564\text{ kN}$$

# Tlaková síla – lomená stena



a)

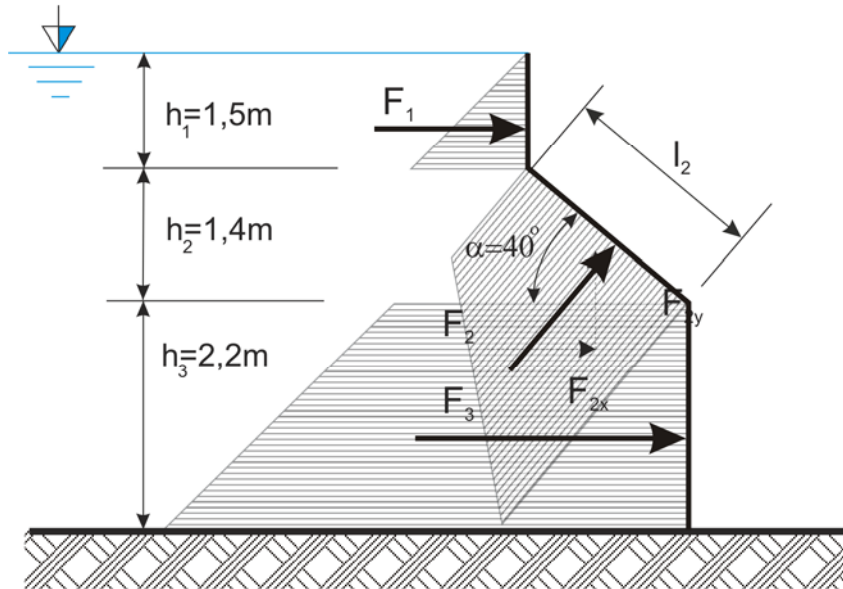

b)

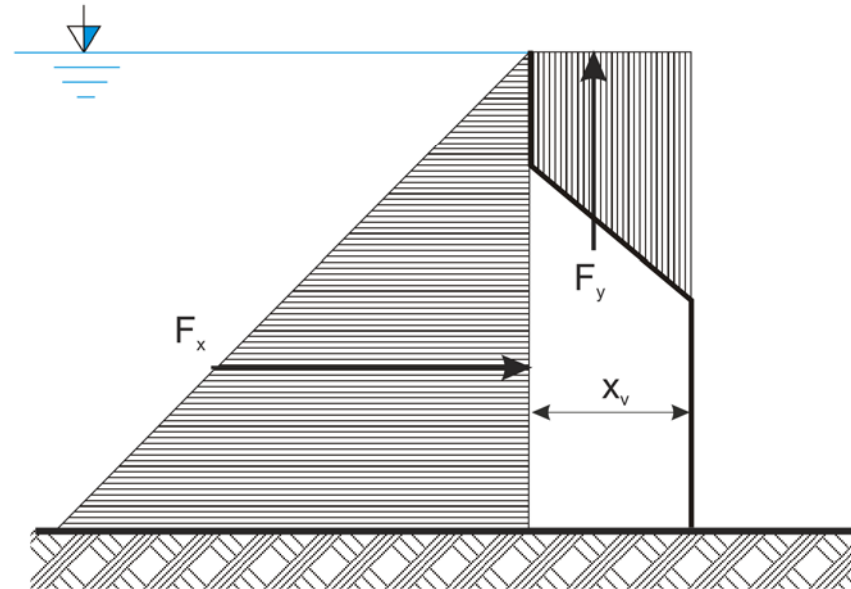

# Príklad – plochy ZO

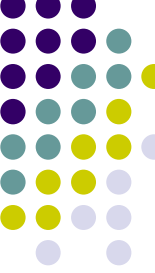

$$S_1 = \frac{1}{2} \cdot h_1^2 = \frac{1}{2} \cdot 1,5^2 = 1,125m^2$$

$$\begin{aligned} S_2 &= \frac{h_1 + (h_1 + h_2)}{2} \cdot l_2 = \frac{2 \cdot h_1 + h_2}{2} \cdot \frac{h_2}{\sin 40^\circ} = \\ &= \frac{2 \cdot 1,5 + 1,4}{2} \cdot \frac{1,4}{\sin 40^\circ} = 4,7916m^2 \end{aligned}$$

$$\begin{aligned} S_3 &= \frac{(h_1 + h_2) + (h_1 + h_2 + h_3)}{2} \cdot h_3 = \frac{2 \cdot h_1 + 2 \cdot h_2 + h_3}{2} \cdot h_3 = \\ &= \frac{2 \cdot 1,5 + 2 \cdot 1,4 + 2,2}{2} \cdot 2,2 = 8,8m^2 \end{aligned}$$



# Príklad – pokrač.

- Sily na úseky

$$F_1 = \rho \cdot g \cdot b \cdot S_1 = 1000 \cdot 9,81 \cdot 1 \cdot 1,125 = 11,036 \text{ kN}$$

$$F_2 = 1000 \cdot 9,81 \cdot 1 \cdot 4,7916 = 47,005 \text{ kN} \quad F_3 = 86,328 \text{ kN}$$

- Rozloženie do smerov x a y a výsledok

$$F_{2x} = F_2 \cdot \cos 50^\circ = 30,214 \text{ kN} \quad F_{2y} = F_2 \cdot \sin 50^\circ = 36,008 \text{ kN}$$

$$F_x = F_1 + F_{2x} + F_3 = 11,036 + 30,214 + 86,328 = 127,578 \text{ kN} \quad F_y = F_{2y} = 36,008 \text{ kN}$$

$$F = \sqrt{F_x^2 + F_y^2} = \sqrt{127,578^2 + 36,008^2} = 132,563 \text{ kN}$$



# Príklad – druhý spôsob

- Vodrovnná zložka

$$S_x = \frac{1}{2} \cdot \left( \sum_{i=1}^3 h_i \right)^2 = \frac{1}{2} \cdot 5,1^2 = 13,005 \text{ m}^2$$

$$F_x = \rho \cdot g \cdot b \cdot S_h = 1000 \cdot 9,81 \cdot 1 \cdot 13,005 = 127,579 \text{ kN}$$

- Zvislá zložka

$$V_v = \frac{h_1 + (h_1 + h_2)}{2} \cdot x_v \cdot b = \frac{2 \cdot h_1 + h_2}{2} \cdot \frac{h_2}{\text{tg}40^\circ} \cdot b =$$

$$= \frac{2 \cdot 1,5 + 1,4}{2} \cdot \frac{1,4}{\text{tg}40^\circ} \cdot 1,0 = 3,6706 \text{ m}^3$$

$$F_y = \rho \cdot g \cdot V_v = 1000 \cdot 9,81 \cdot 3,6706 = 36,008 \text{ kN}$$

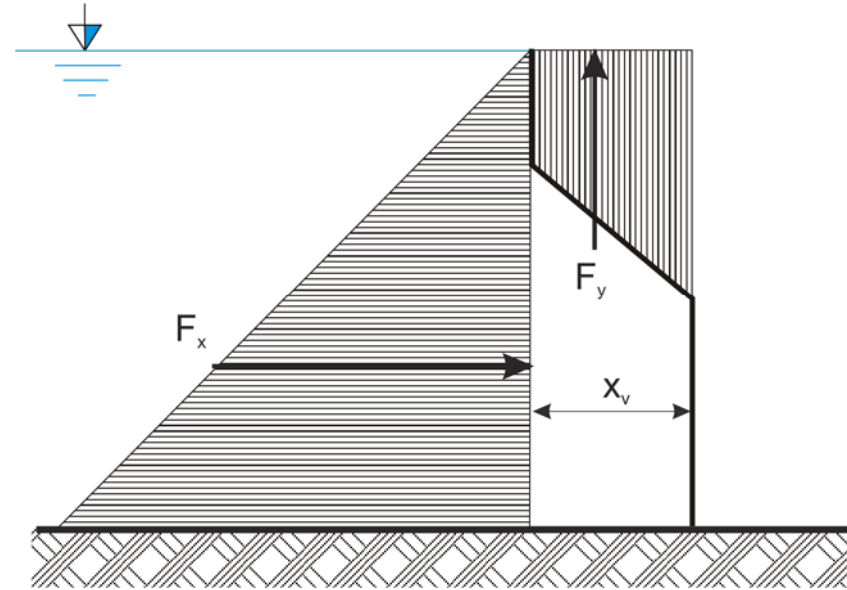

$$F = \sqrt{F_h^2 + F_v^2} = \sqrt{127,579^2 + 36,008^2} = 132,563 \text{ kN}$$

# Zakrivené steny

- Príklad

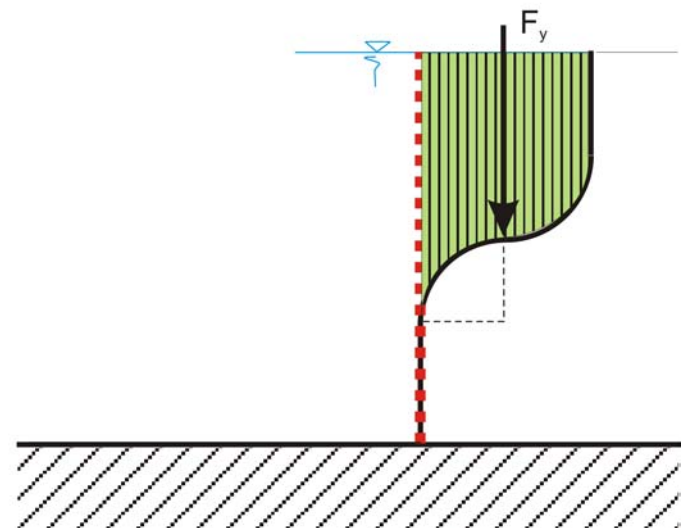
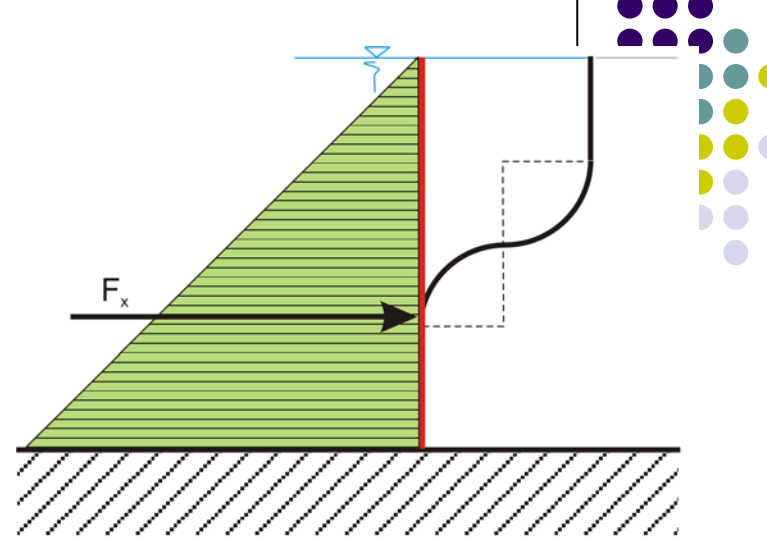
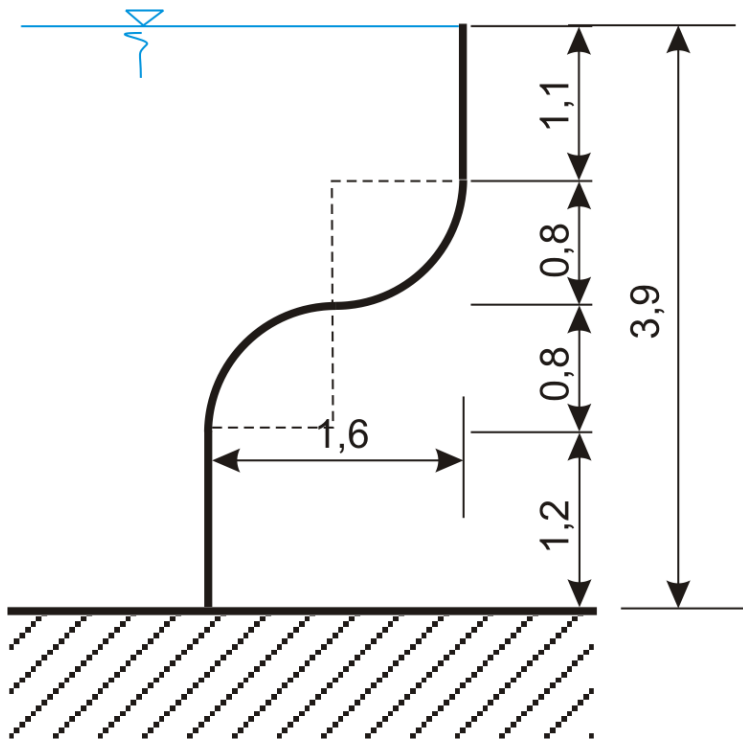

# Riešenie príkladu

- Vodrovnná zložka

$$S_x = \frac{1}{2} \cdot 3,9^2 = 7,605$$

$$F_x = \rho \cdot g \cdot b \cdot S_x = 1000 \cdot 9,81 \cdot 1,0 \cdot 7,605 = 74605,05 \text{ N} = 74,60505 \text{ kN}$$

- Zvislá zložka

$$S_y = 1,9 \cdot 1,6 = 3,04$$

$$F_y = \rho \cdot g \cdot b \cdot S_y = 1000 \cdot 9,81 \cdot 1,0 \cdot 3,04 = 29822,4 \text{ N} = 29,8224 \text{ kN}$$

- Výslednica

$$F = \sqrt{F_x^2 + F_y^2} = \sqrt{74,60505^2 + 29,8224^2} = 80,3448 \text{ kN}$$

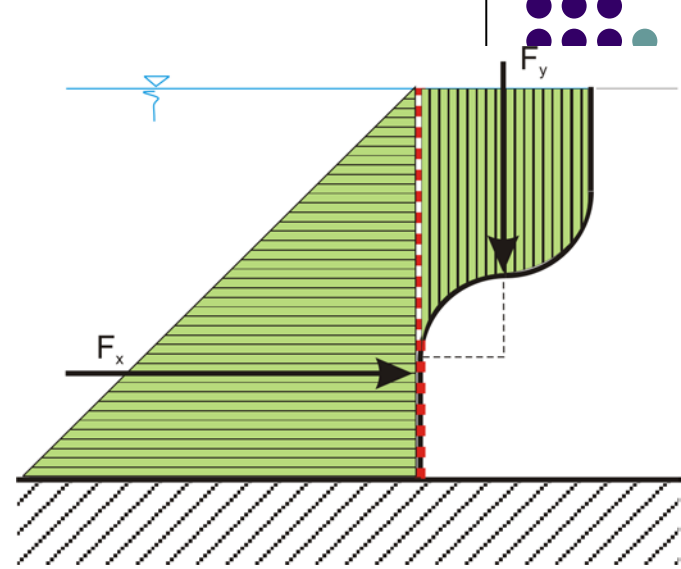

# Plávanie telies

- Archimédov zákon

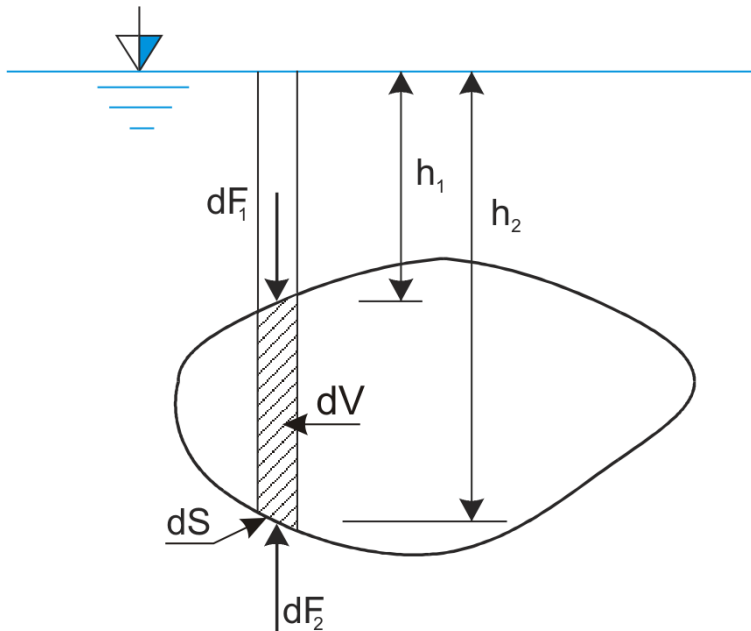

$$dF_1 = (p_0 + \rho \cdot g \cdot h_1) \cdot dS$$

$$dF_2 = (p_0 + \rho \cdot g \cdot h_2) \cdot dS$$

$$dF = dF_2 - dF_1 = \rho \cdot g \cdot (h_2 - h_1) \cdot dS$$

$$dF = \rho \cdot g \cdot dV$$

$$F = \int_V dF = \rho \cdot g \cdot \int_V dV = \rho \cdot g \cdot V$$

Vztlaková sila je rovná tiaži vody, vytlačenej telesom

# Stabilita plávajúcich telies

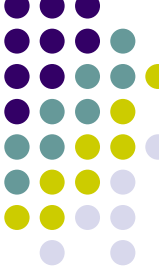

- Tri druhy
  - Stabilná – metacentrum nad ťažiskom
  - Labilná – metacentrum pod ťažiskom
  - Indiferentná – metacentrum priamo v ťažisku

